

Signature Series

Maximum Resilience Broadcast Audio



Signature ADA 1:8G 8 Way Mono Distribution Amplifier With Output Gain



ADA 1:8G Front



ADA 1:8G Rear

FEATURES

**1 x mono input to
8 x mono outputs**

**Each output has
individual gain
controls**

**Outputs can be
connected
balanced or
unbalanced**

**Input can be
connected
balanced or
unbalanced**

The Signature ADA 1:8G is a broadcast specification 8 way mono analogue distribution amplifier, designed to distribute one audio channel to multiple destinations.

The ADA 1:8G has 1 x mono input that is distributed to 8 x mono outputs, each with its own gain control.

Audio inputs and outputs are electronically balanced on XLRs and can accommodate unbalanced connections if required. The output gains are on front panel multi-turn potentiometers which are recessed to prevent accidental operation.

They provide a wide gain range to cope with the different gain level requirements of broadcast or domestic level equipment. All outputs are protected, so a short circuit on one will not affect any of the others.

Power is provided by an internal switch mode power supply, with a wide input range. There is also an input for external 12V DC power. The 12V DC input can be connected to the optional Signature PS1 external DC Master Power Station, for situations where a redundant power supply is desirable.

A bright front panel LED indicates that the unit is operational.

Signature ADA 1:8G 8 Way Mono Distribution Amplifier With Output Gain

EXAMPLE APPLICATION

AM Radio Station CTA Six Output Mono Distribution (With 2 Spare)

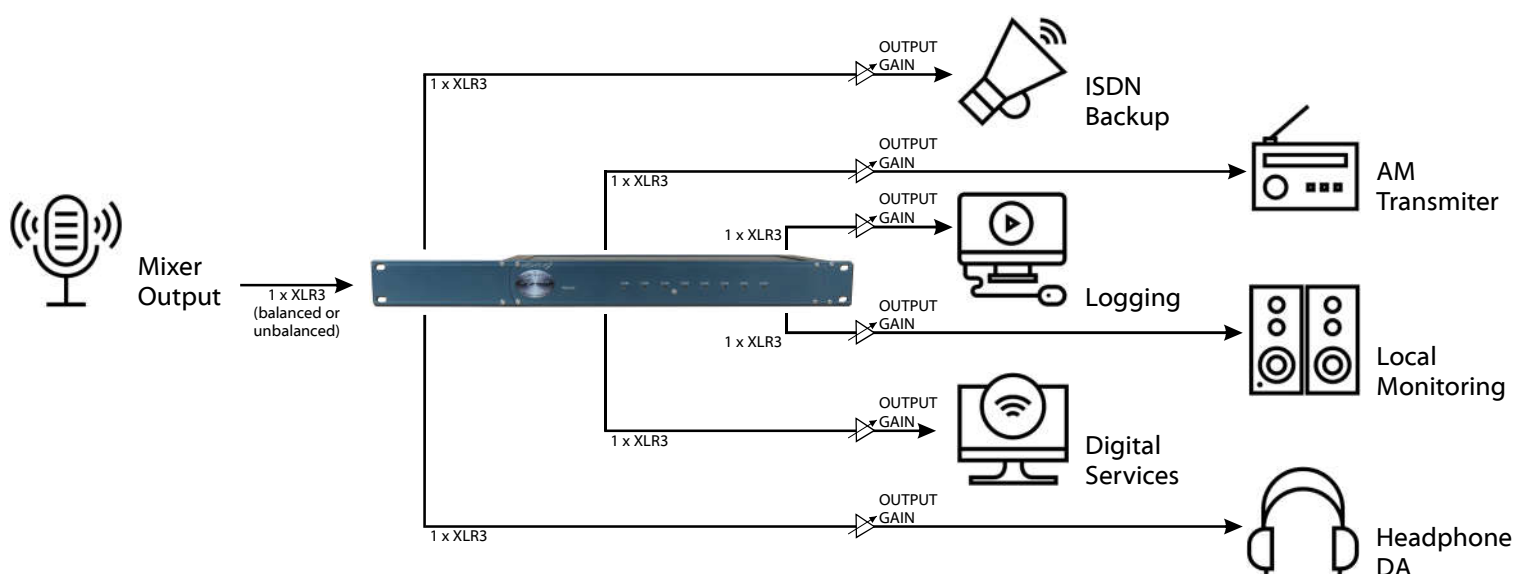

The main mono programme audio from a radio station needs to be distributed across multiple platforms. The output from the desk or automation system no longer just heads off to the transmitter. The audio must be distributed across all of the relevant services that require a connection of the original programme audio.

In this example, the Signature ADA 1:8G provides 6 mono outputs of the main programme audio, leaving 2 spare. One output connects to the transmitter as the main AM broadcast feed. As multiple guest headphones are required in the studio, another output connects to a separate headphone distribution amplifier. This station also broadcasts online, so another output connects to a PC to become the internet broadcast stream. Local monitoring is required, so one feed goes to the local monitoring system.

The transmitter B chain is on ISDN, so one output goes to an ISDN codec. And the final output connects to another PC that manages all of the station's logging requirements.

All of these distributed sources may require different levels. With the Signature ADA 1:8G, each distributed output can have a different gain level set so that it matches the incoming level requirements of each source. For example, the feed that goes to the AM transmitter link will be connected to professional equipment expecting normal line up levels. However, the station logging may be on a domestic grade PC and require a much higher input level to be sent to it. Using the ADA 1:8G, a separate gain level can be set for each output.

It's very easy to see why multiple outputs of the main programme audio are required, with different gain levels, in a typical radio station environment.



Signature Series

Maximum Resilience Broadcast Audio



Signature ADA 1:8G
8 Way Mono Distribution Amplifier With Output Gain

EXAMPLE APPLICATION

Commentary Feed In IBC Eight Output Mono Distribution

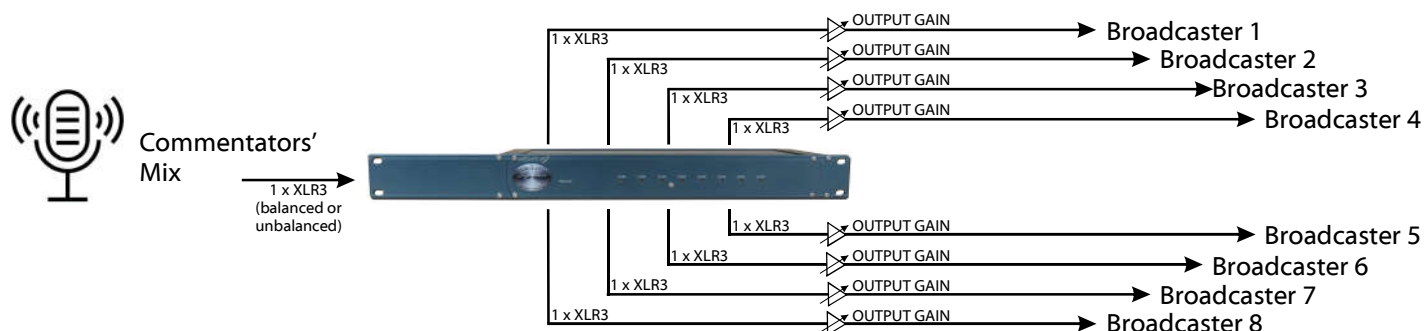

A single channel mono feed is connected to the Signature ADA1:8G. This could be the master programme mix output from a host commentary system at a sports stadium. This needs to be distributed to all the relevant broadcasters who want to take the host commentary audio.

Eight outputs from the ADA1:8G are available, which all contain the original audio, and are available to distribute to all of the relevant 8 broadcasters. As the required levels may be different for each broadcaster, the gain can be adjusted independently for each output.

SPECIFICATION

AUDIO

Frequency Response	<-0.5dB 20Hz to 20kHz
Gain Range	-10dB to +15dB on each output
Maximum Input Level	>+28dB
Maximum Output Level	+24dBu
Input Impedance	>30k Ohm
Output Impedance	=<50 Ohms
Distortion	0.013% THD @ 100Hz, 1kHz & 10kHz Reference to +8dBu output
Noise	-89dB @ line up unweighted RMS (22Hz to 22kHz)
Common Mode Rejection	Circa -63dB @ lineup
Output Type	Electronically balanced (can be wired unbalanced) on Neutrik 3 pin XLR plug
Input Type	Electronically balanced (can be wired Unbalanced) on Neutrik 3 pin XLR socket

POWER

Mains Input	Filtered IEC, 100 to 240VAC 47 - 63Hz
AC Consumption	2.15 Watts @ 230VAC
DC Input	4 Pin Neutrik XLR plug +/- 12V
Internal Mains Fuse	20mm 1A Anti Surge

PHYSICAL

Size	336 x 123 x 44mm (LxDxH) no rack ears 482mm 19" (1RU) with rack ears
Weight	0.98kg
Mechanics	All aluminium construction, anodized and laser etched
Shipping Carton	Rugged export quality cardboard carton 610 x 420 x 130mm LxDxH
Shipping Weight	2.4kg

E & OE

Signature Series

Maximum Resilience Broadcast Audio



Signature ADA 1:8G
8 Way Mono Distribution Amplifier With Output Gain

AUDIO BLOCK DIAGRAM

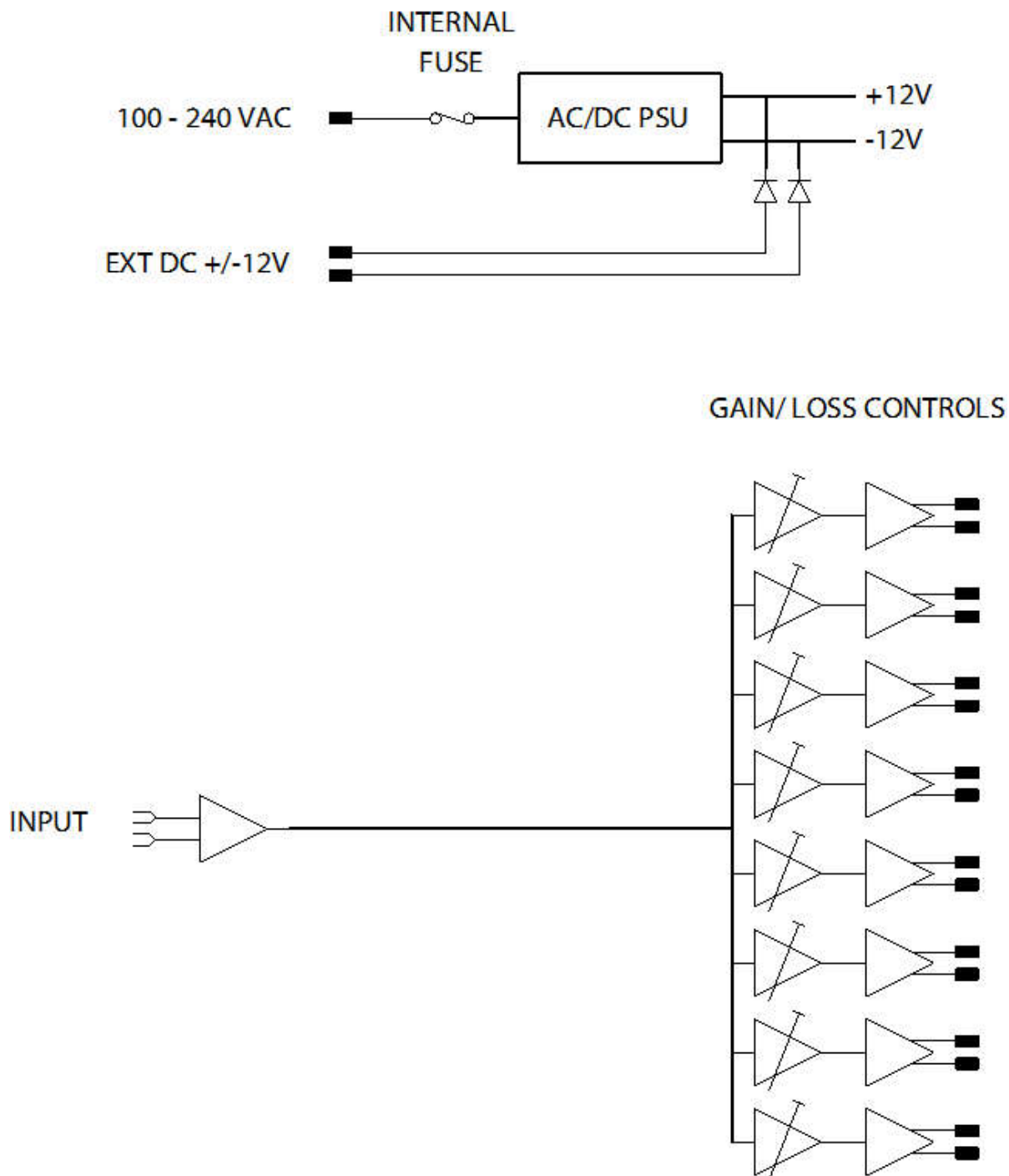

Signature Series

Maximum Resilience Broadcast Audio



Signature Series Standard Features

STANDARD FEATURES

19" Rack Mount Ears



A Signature unit can rack mount in a 1U 19" rack, regardless of the size of the unit. Rack ears are included as standard with every unit.

Front Or Rear Mounting



A Signature unit can be rack mounted via the front panel or if it is more convenient, via the rear panel by simply swapping the rack ears over.

Side Wings For Flat Surface Fixing



A Signature unit has side wings with mounting holes at the top and bottom, allowing flush fixing from above OR underneath.

Neutral Colour Scheme To Complement Equipment Areas



Rack Screws Included



Modern Design



Internal Switch Mode AC Power Supply



A Signature unit has an internal switch mode AC power supply, allowing worldwide power connections from 100-240V via an IEC socket.

12V DC Power Connection



All Signature units (except PS1) have a 4 pin XLR $\pm 12V$ DC socket for connection to the PS1 Power Station. This can act as the primary or backup power source.

Quick Find Manual



A Signature unit has a QR code attached. This can be scanned to simply and quickly locate the manual and technical information.

CONTACT

Glensound
6 Brooks Place, Maidstone
Kent, UK, ME14 1HE
Tel: +44 (0)1622 753 662
Web: www.glensound.com
Email: sales@glensound.com

Glensound
Keeps Working