



**Glensound**  
Keeps Working

# Charles

**Dante interpreter's interface**

**PRODUCT DETAILS**



# GlenSound Electronics Ltd

Thank you for choosing a new GlenSound product.

All rights reserved.

Information contained in this manual is subject to change without notice, if in doubt please contact us for the latest product information.

If you need any help with your product then we can be contacted at:

GlenSound Electronics Ltd  
1 – 6 Brooks Place  
Maidstone  
Kent  
ME14 1HE  
United Kingdom

Telephone: +44 (0) 1622 753662

Fax: +44 (0) 1622 762330

## EMAIL ADDRESSES

General and Technical enquires: [office@glenSound.com](mailto:office@glenSound.com)

Sales enquires: [sales@glenSound.com](mailto:sales@glenSound.com)

# IMPORTANT SAFETY INSTRUCTIONS

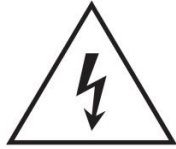

This symbol is intended to warn that dangerous voltages within the product are present and constitute a risk of electric shock.



This symbol is intended to highlight that there are important operating & maintenance instructions in the literature accompanying this unit.



This symbol is intended to highlight that the equipment must have a valid earth connection with the protective earthing conductor.

This product is fitted with an internal ceramic fuse cartridge.  
In the event of fuse blow, a replacement fuse must exhibit the follow specifications:  
Rating: 250VAC 2A  
Sand/silica filled  
Time delay blow  
5mm x 20mm



High sound pressure  
Hearing damage risk  
Do not listen at high volume levels for long periods.

	<b>CAUTION</b> RISK OF ELECTRICAL SHOCK DO NOT OPEN	
CAUTION: TO REDUCE THE RISK OF ELECTRIC SHOCK, DO NOT REMOVE COVER (OR BACK) . NO USER-SERVICABLE PARTS INSIDE. REFER TO SERVICING TO QUALIFIED PERSONNEL.		

**WARNING:**

To reduce the risk of fire or electric shock, do not expose this product to rain or moisture.

- 1) Read these instructions
- 2) Keep these instructions
- 3) Heed all warnings
- 4) Follow all instructions
- 5) This product is intended for indoor use only
- 6) The intended ambient operating temperature of this product is 0°C to 40°C
- 7) Do not use this apparatus near water
- 8) Clean only with a dry cloth
- 9) Do not block any ventilation openings. Install in accordance with manufacturer's instructions
- 10) Do not install near any heat sources such as radiators, heat registers, stoves, or other apparatus (including amplifiers) that produce heat
- 11) Do not defeat the safety purpose of the polarized or grounding type plug. A polarized plug has 2 blades with one wider than the other. A grounding type plug has 2 blades and third grounding prong. The wider blade or the 3<sup>rd</sup> prong are provided for your safety. If the provided plug does not fit into your outlet, consult an electrician for replacement of the obsolete outlet
- 12) Protect the power cord from being walked on or pinched, particularly at plugs, convenience receptacles and the point where they exit from the apparatus
- 13) The socket outlet used for mains power to this device must be easily accessible
- 14) Only use attachments/ accessories specified/ supplied by the manufacturer
- 15) Use only with the cart, stand, tripod, bracket, or table specified by the manufacturer, or sold with the apparatus. When a cart is used, use caution when moving the cart/ apparatus combination to avoid injury from tip over
- 16) Unplug this apparatus during lightning storms or when unused for long periods of time
- 17) Refer all servicing to qualified service personnel. Servicing is required when the apparatus has been damaged in any way, such as power supply cord or plug is damaged, liquid has been spilled or objects have fallen into the apparatus, the apparatus has been exposed to rain or moisture, does not operate normally, or has been dropped
- 18) Do not attempt to modify this product. Doing so could result in personal injury and/ or product failure



## **PRODUCT WARRANTY**

All equipment is fully tested before dispatch and carefully designed to provide you with trouble free use for many years.

We have a policy of supporting products for as long as possible and guarantee to be able to support your product for a minimum of 10 years.

For a period of one year after the goods have been despatched the Company will guarantee the goods against any defect developing after proper use providing such defects arise solely from faulty materials or workmanship and that the Customer shall return the goods to the Company's works or their local dealer.

All non-wear parts are guaranteed for 2 years after despatch and any defect developing after proper use from faulty materials or workmanship will be repaired under this warranty providing the Customer returns the goods to the Company's works or their local dealer.



## EU DECLARATION OF CONFORMITY

### **Charles**

*Dante interpreter's interface*

This declaration of conformity is issued under the sole responsibility of the manufacturer.

This equipment is manufactured by Glensound Electronics Ltd of Brooks Place Maidstone Kent ME14 1HE is  marked and conforms to the following Union harmonisation legislation:

Emissions: BS EN55032:2015

Immunity: BS EN55035:2017

Signed for and on behalf of Glensound Electronics Ltd.

A handwritten signature in blue ink, appearing to read 'M. Wilson', is positioned above the printed name of the signatory.

Marc Wilson, Managing Director  
Maidstone, Kent, England

Date: 22/03/2023

## **RoHS DIRECTIVE**

RoHS 2 Directive 2011/65/EU restricts the use of the hazardous substances listed below in electrical and electronic equipment.

This product conforms to the above directive and for these purposes, the maximum concentration values of the restricted substances by weight in homogenous materials are:

Lead	0.1%
Mercury	0.1%
Hexavalent Chromium	0.1%
Polybrominated Biphenyls	0.1%
Polybrominated Diphenyl Ethers	0.1%
Cadmium	0.01%

## **WASTE ELECTRICAL AND ELECTRONIC EQUIPMENT REGULATIONS 2006 (WEEE)**

GlenSound Electronics Ltd is registered for business to business sales of WEEE in the UK our registration number is:

**WEE/JJ0074UR**

# GLENSOUND Charles

## Handbook Contents

<u>Description</u>	<u>Page No.</u>
<b>Contents</b>	
<b>IMPORTANT SAFETY INSTRUCTIONS .....</b>	<b>3</b>
<b>PRODUCT WARRANTY .....</b>	<b>4</b>
<b>CE .....</b>	<b>5</b>
<b>RoHS DIRECTIVE.....</b>	<b>6</b>
<b>WASTE ELECTRICAL AND ELECTRONIC EQUIPMENT REGULATIONS 2006 (WEEE)....</b>	<b>6</b>
<b>Handbook Contents .....</b>	<b>7</b>
<b>Overview.....</b>	<b>9</b>
<b>Charles front panel layout.....</b>	<b>10</b>
Mic / Line In (for goose neck) .....	10
Headphone socket .....	10
Master headphone volume.....	10
Headphone EQ (tone) controls.....	10
Listen Level Controls .....	11
Talk to buttons .....	11
Listen to buttons .....	11
Microphone On button .....	11
Peak Programme Meter (PPM).....	11
Power On LED.....	11
<b>Configuring the microphone on button .....</b>	<b>11</b>
<b>Charles rear panel layout.....</b>	<b>12</b>
Mic/ Line Select.....	12
Phantom Power (48V) Select.....	12
Input Gain .....	12
Power Status LEDs .....	13
Primary & Secondary CAT5 Network Ports .....	13
Primary & Secondary SFP Fibre Network Ports .....	13
12V DC Power Inlet.....	13
USB Connector.....	13
Update Switch (sidetone adjustment).....	13
IEC Mains Inlet.....	13
<b>Audio Block Diagram .....</b>	<b>14</b>
<b>Connecting The Charles To A Dante Network.....</b>	<b>15</b>
Getting Dante Controller .....	15
Connecting Charles device to the network.....	15

Audio Over IP Network .....	15
Running Dante Controller .....	16
Dante Controller TIP .....	16
Device not showing up in Dante Controller .....	17
<b>AES67 Mode .....</b>	<b>18</b>
Turning On AES67 Mode.....	18
Sending AES67 Audio .....	18
Receiving AES67 Audio.....	19
AES67 Restrictions .....	20
<b>Updating device firmware .....</b>	<b>21</b>
Equipment needed .....	21
Instructions.....	21
Download and install DfuSE Demo .....	21
Download firmware .....	21
Connect To A PC.....	21
Firmware update preparation .....	22
Loading the firmware .....	22
Upgrading the Charles firmware .....	23
Final steps .....	25
<b>Updating the Dante firmware .....</b>	<b>26</b>
Updating the device .....	26
<b>Wiring Information .....</b>	<b>28</b>
XLR & Jack Wiring.....	28
Optional 5 Or 4 Pin XLR Wiring Information .....	28



## **Overview**

The Glen sound Charles is a single user translator's box designed to connect to a Dante audio network. The Charles provides all the facilities required by a translator whilst incorporating a very high quality microphone amplifier and compressor limiter circuit designed specifically for the requirements of translator's equipment.

The audio inputs and outputs of the Charles are Dante network audio circuits. Dante network audio is a common protocol for distributing high quality linear audio over standard IP networks and it is widely used by many audio equipment manufacturers. The Glen sound Charles's Dante audio interface will be compatible with any other manufacturers Dante audio interface. Further details of Dante network audio can be found at [www.audinate.com](http://www.audinate.com)

Intended for live on-air broadcast applications; the Glen sound Charles has been designed with multiple redundancy capabilities. It has 4 possible sources of power (Mains, 2 x PoE & 1 external DC) and it also has fully redundant network connections for both Copper & Fibre circuits.

Charles includes intelligent automatic level ducking features that allow for the interpreted audio channel to include the pre translated speech when the translator is not talking or has not enabled the microphone. This simplifies the broadcast signal chain and can remove the need for additional equipment to process your interpretation. Please see the [Audio block diagram](#) for more information.

## Charles front panel layout

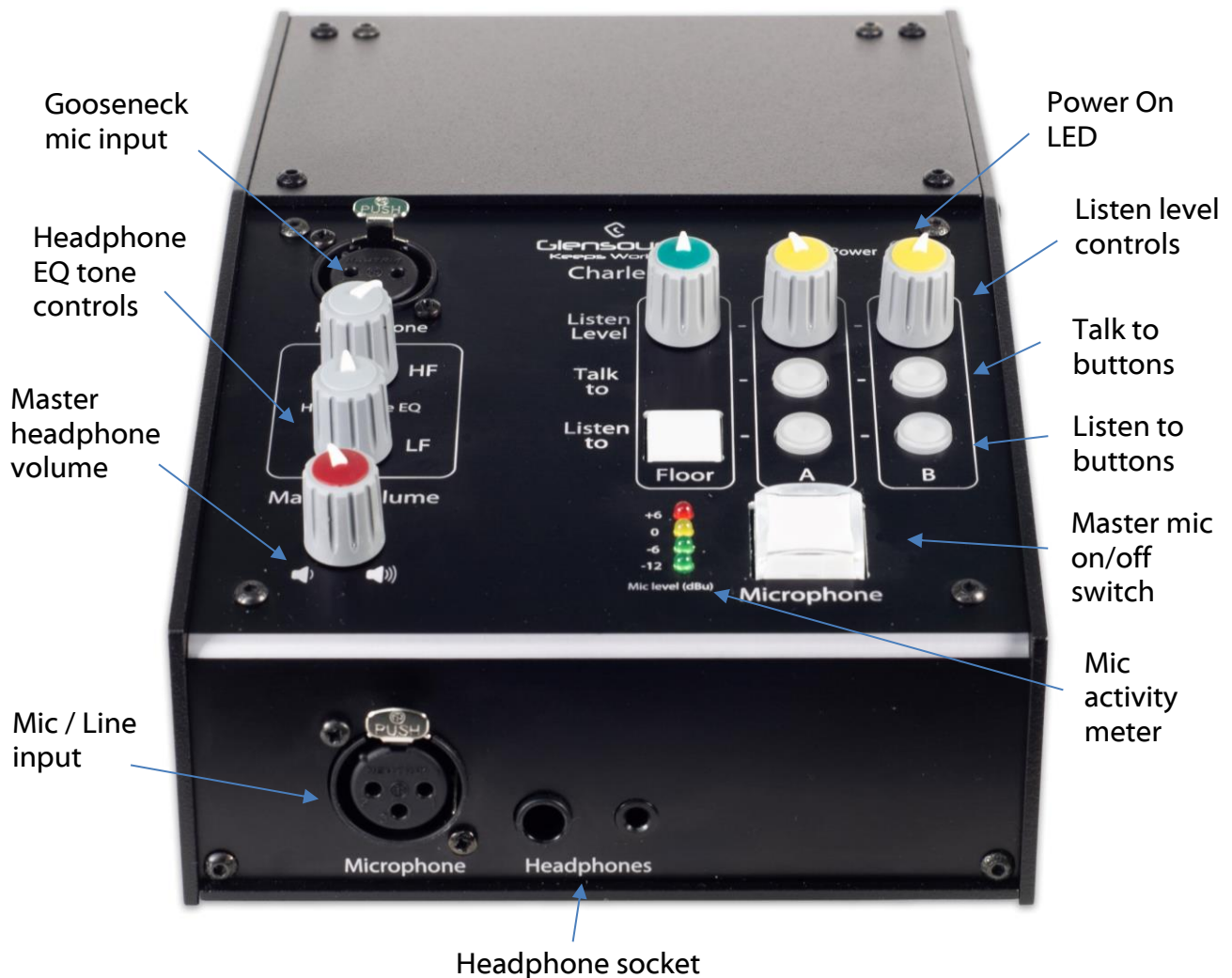

### Mic / Line In (for goose neck)

There are two 3 pin XLR sockets on the Charles to facilitate the use of a gooseneck microphone or XLR microphone headset. Only one microphone can be used at a time and the ports can also be used in line mode to accept one line level input instead.

### Headphone socket

3 pin stereo 6.35mm or 3.5mm jack sockets allows for one pair of headphones to be connected for the interpreter.

### Master headphone volume

This control adjusts the overall level of the headphones.

### Headphone EQ (tone) controls

Use these controls to adjust the frequency response of the headphone audio to help speech intelligibility.

## **Listen Level Controls**

These potentiometers (Floor A, and B) adjust the headphone volume of the associated input circuit being received across the Dante network.

## **Talk to buttons**

The 2 round illuminated 'talk to' switches route the translator's mic to the output of the Charles i.e. A or B channels of the Dante network. Only one talk destination may be selected at any time.

## **Listen to buttons**

The square illuminated 'Floor' and 2 round illuminated A / B switches allow the translator to listen to either the 'Floor' audio, or that of translator A or B. Only one listen source may be selected at any time.

## **Microphone On button**

This large square illuminated switch routes the output of the translator's mic to the Dante network. The operation of this switch (momentary, latching, intelligent lever key etc) can be configured – see below.

## **Peak Programme Meter (PPM)**

A 4 LED PPM indicating the output level of the main on-air circuit. The 4 LEDs indicate -12, -6, 0, and +6dBu.

## **Power On LED**

There is no power on / off switch on the Charles and it is safe to leave it on 24/7. The front panel power on LED provides a confidence indication that the unit is powered on and working correctly.

## **Configuring the microphone on button**

To enter configuration mode, press and hold the 'Talk to A' and 'Talk to B' buttons, then apply power

The microphone button colour indicates the current mode. Press the microphone button to cycle through the modes. The PPM LEDs indicate the mode.

+6 RED	- cough
0 YELLOW	- momentary only
-6 GREEN	- latching only
-12 GREEN	- latching and momentary

Power cycle the unit to save the configuration.

## Charles rear panel layout

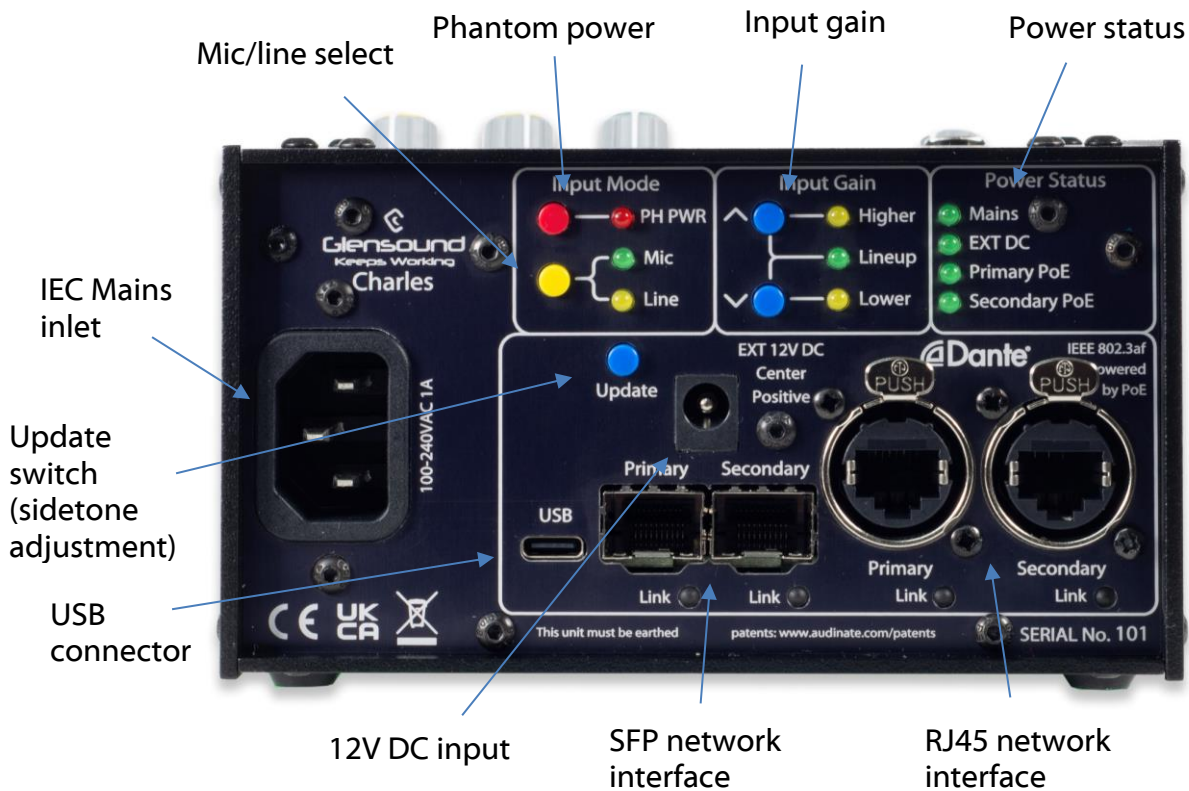

### Mic/ Line Select

Pressing the switch toggles the coarse input gain between mic and line as indicated by the LEDs.

### Phantom Power (48V) Select

This switch turns the phantom power on/off. Phantom power cannot be turned on if the input mode is set to 'Line'.

### Input Gain

The up/ down push buttons increase/ decrease the units gain. Each time a button is pressed the gain increases/ decreases by about 0.33 dB.

The 'LINEUP' LED indicates when the gain is in the factory pre-set lineup condition which is:

INPUT SELECTED	GAIN OF MIC AMP	OUTPUT LEVEL
MIC	58dB	0dB
MIC + PH PWR	35dB	0dB
LINE	0dB	0dB

The 'HIGHER' / 'LOWER' LEDS indicate where the current gain setting is in relation to line up

Holding BOTH up/ down gain controls for a few seconds returns the input gain to factory lineup levels.

## **Power Status LEDs**

For redundancy purposes the Charles can be powered from multiple power sources. It can be powered from any of the following:

- A. Mains (100-240VAC)
- B. EXT DC (12V)
- C. Power Over Ethernet (PoE) on the primary CAT5 network connection
- D. Power Over Ethernet (PoE) on the secondary CAT5 network connection

The LEDs indicate which power sources are currently active.

## **Primary & Secondary CAT5 Network Ports**

These 2 standard network ports can be connected to your IP network.

## **Primary & Secondary SFP Fibre Network Ports**

Standard SFP Fibre network interface modules can be fitted in these 2 ports. SFP modules are available in many different formats, if required Glensound can supply suitable SFP modules, contact [sales@glensound.co.uk](mailto:sales@glensound.co.uk) for further information.

## **12V DC Power Inlet**

This is a 2 pin barrel type DC input connector. The centre pin is 2.5mm. It is wired centre pin + Volts. It is designed to accept a + volt DC input between 9 and 15 volts. The connector has a barrel locking mechanism allowing specialist locking barrel connectors to be used, a suitable mating part is manufactured by KYCON and their part number is KLDX-PA-0202-B-LT

## **USB Connector**

This is used for connecting a PC to the Charles for updating its firmware.

## **Update Switch (sidetone adjustment)**

Press and hold this switch to enable sidetone level adjustment.

Whilst holding the update switch, the front panel will change and 'Talk to' and 'Listen to' buttons for channel A flash and now become up and down sidetone level adjustments.

When the maximum level is reached the upper button will stop flashing and illuminate solidly, and when the minimum level is reached the lower button will stop flashing and illuminate solidly. Release the update switch to save the configured sidetone level.

Pressing and holding the update switch during power up will boot the unit in to it's firmware update mode.

## **IEC Mains Inlet**

3 pin IEC Mains inlet accepting a mains input range of 100 – 240 VAC.

\*\*\*\*\*THIS UNIT MUST BE EARTHED\*\*\*\*\*

# AUDIO FROM DANTE

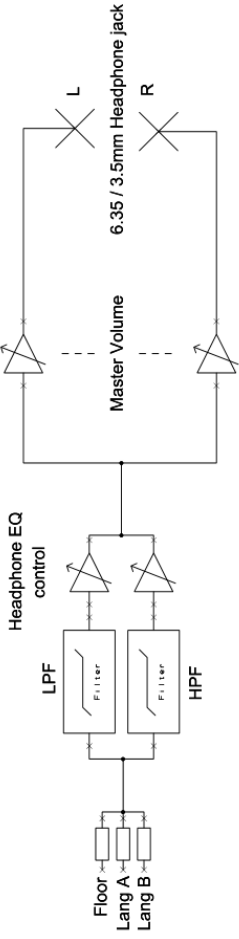
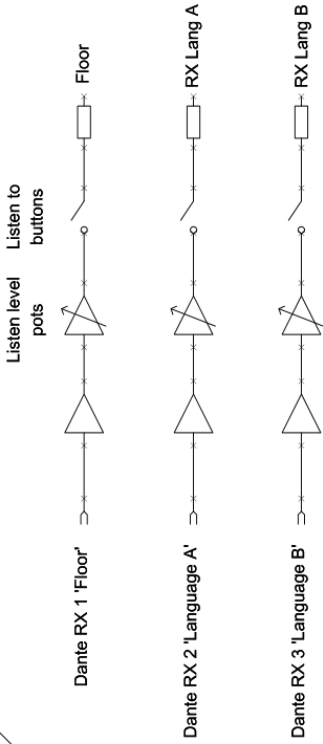

# AUDIO TO DANTE

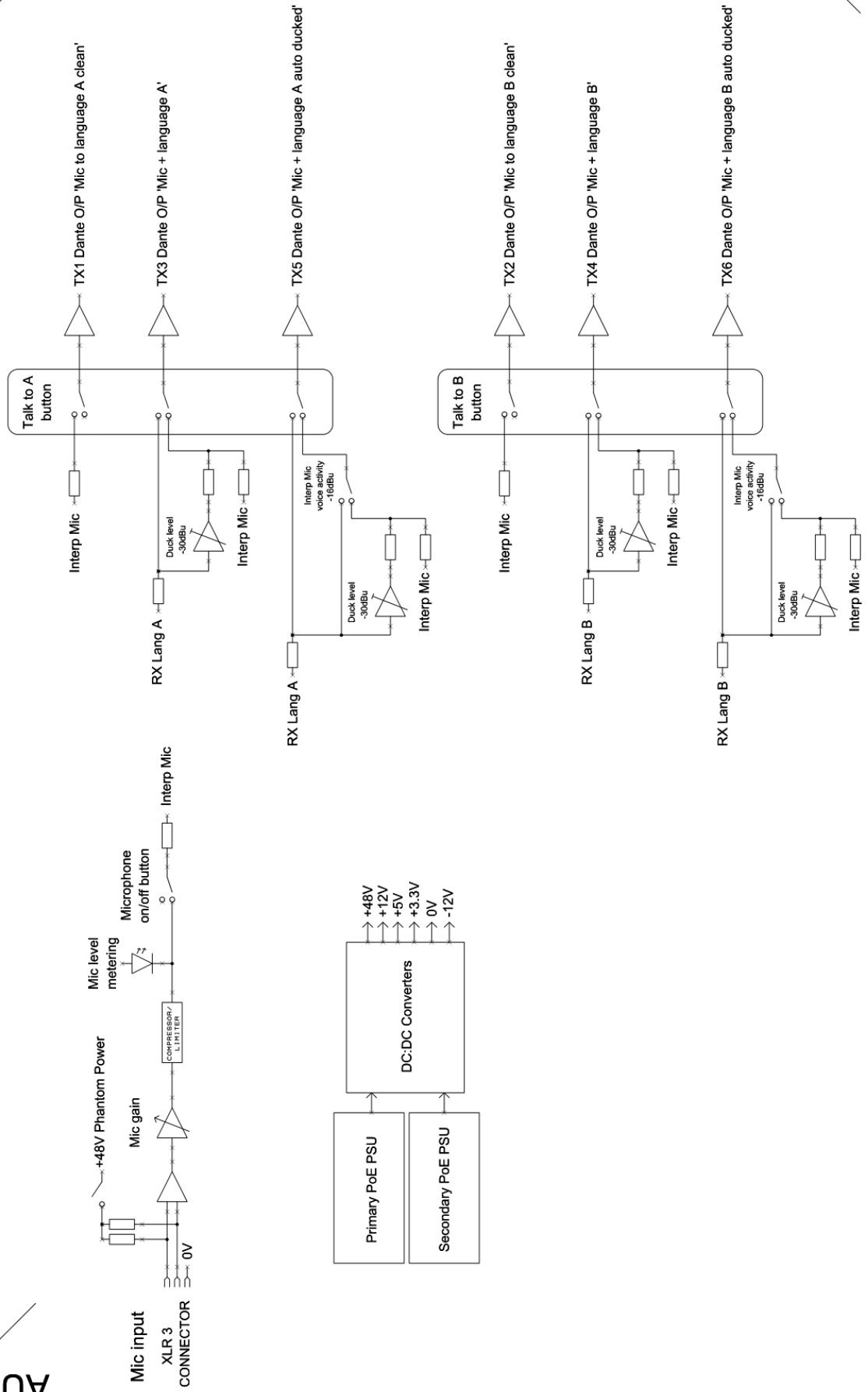

## **Connecting The Charles To A Dante Network**

The Charles is a network audio device utilizing the reliable and versatile Dante audio over IP protocol. Dante is a proprietary system (although very widely used) the originators of which are Audinate.

The information below is only meant as a very basic guide. Full details of the power of Dante network audio and instructions for using it can be found at [www.audinate.com](http://www.audinate.com)

### **Getting Dante Controller**

If you are connecting the Charles to a new Dante network the first thing you will need to do is to get the free Dante controller software from Audinate.

This can be downloaded by visiting Audinate's web site at [www.audinate.com](http://www.audinate.com)

### **Connecting Charles device to the network**

The Charles can be connected to the network that you are going to use for your audio distribution simply by plugging in to the RJ45 network connections on the rear. Once connected to the network it will be possible to see the Charles from within the Dante controller and route its' audio circuits.

### **Audio Over IP Network**

We strongly recommend that you consider your network topology carefully and would not recommend sharing broadcast audio and general data on the same network.

For more details of audio over IP network structure please visit [www.audinate.com](http://www.audinate.com)

## Running Dante Controller

At the time of writing this manual the Dante Controller looks as per the screenshot below:

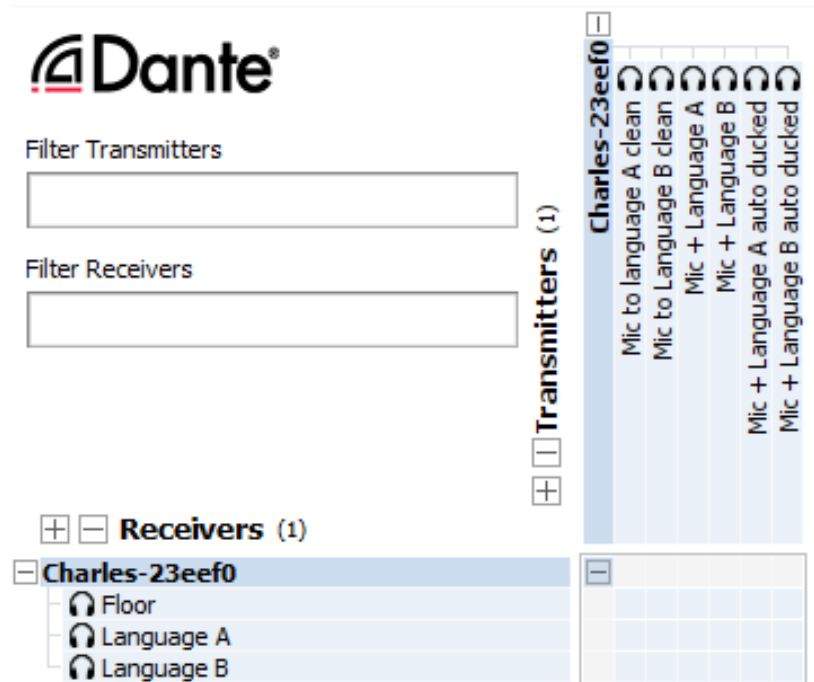

The Charles will have been named at the factory during test to allow them to be identified by the Dante controller.

The format used for the factory name is:

'Charles-SN-XXXX'

Where 'Charles' refers to the Glensound product i.e. Charles

The 'SN-XXXX' refers to the serial number of the Charles which can be found printed on the rear or side of the unit.

The unit may be renamed in Dante controller by opening the 'Device view' window and selecting Charles in the drop-down menu. Go to the 'Device Config' tab and change the name with the Rename Device box.

Note if you upload a new DNT file or clear the devices config then the name will change to 'Charles-xxXxXx' whereby the 'X's refer to the devices MAC address.

### Dante Controller TIP

If you have never run Dante controller before then make sure that on the bottom left of the Dante controllers' screen 'P' or 'S' is next to a green square as this indicates that it is connected to a network. By clicking 'P' or 'S' a pop up box opens to allow you to set what network interface the controller is using.



## Device not showing up in Dante Controller

If your Dante device does not show up in Dante Controller then the most likely issue is that the device's IP Address is not appropriate for your network.

- A) It maybe that the device is set to obtain an IP address automatically using DHCP (this is the default configuration) and your network is setup for fixed IP addresses only and does not have a DHCP server.
- B) It maybe that the device has had a fixed IP address assigned but that this address is not suitable for your network.

The solution to both scenarios is basically the same.

- 1) You must connect your Dante device directly to the Ethernet port of your computer using an Ethernet cable.
- 2) Make sure that your computer is set to 'Obtain an IP address automatically'
- 3) After a few minutes the Dante device should now appear in Dante Controller.
- 4) Double click the device name to open up device view.
- 5) Open up the 'Network Config' tab
- 6) Either turn on 'Obtain an IP Address Automatically' or correctly configure the 'Manually configure an IP Address' options for your network.
- 7) Click on 'Apply' to confirm the new settings, then disconnect the computer and reconnect the Dante device to your network.

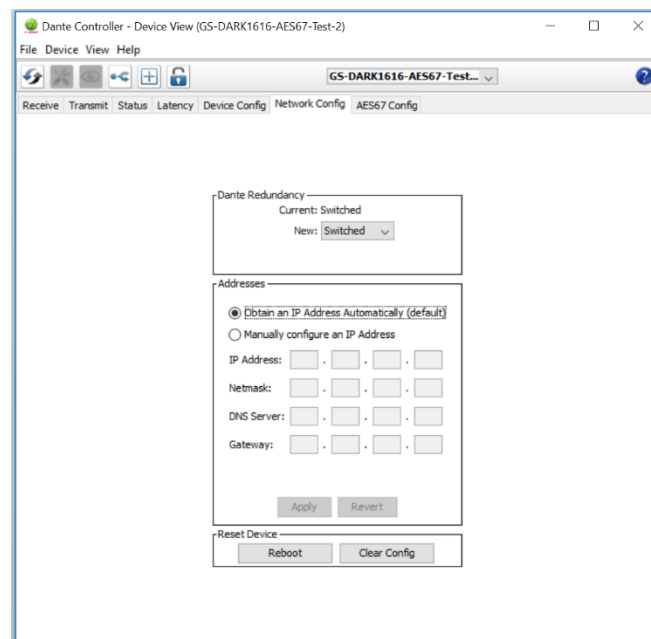

## **AES67 Mode**

The Charles uses a chipset from Audinate called the Brooklyn for its network audio interface. Audinate are the company behind Dante and as such the primary network audio protocol is Dante, however Audinate have enabled their chip to comply with AES67 and therefore the Charles can be set to AES67 mode for interaction with other AES67 devices.

Please note however that Glensound are relying on Audinate's AES67 interface and are unfortunately not able to provide full AES67 support for the unit. AES67 support should be sought directly from Audinate.

## **Turning On AES67 Mode**

If you want to use your Charles on an AES67 network and it has not been set to AES67 mode then this can be set in Dante controller by double clicking the Charles to open the Device View window where you will find an AES67 tab to enable AES67 support.

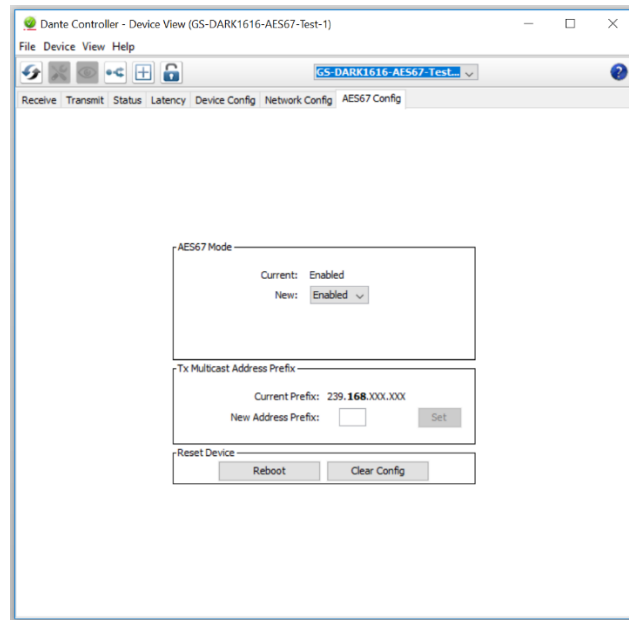

Once the AES67 drop down box has been enabled you'll have to reboot the Charles for the change to take effect. After the reboot go back to the AES67 tab and set the multicast prefix address to one that is suitable for your network.

## **Sending AES67 Audio**

To transmit AES67 audio to the network a multicast flow must first be setup.

This is done by selecting the 'Create New Multicast Flow' Icon  in the Device View.

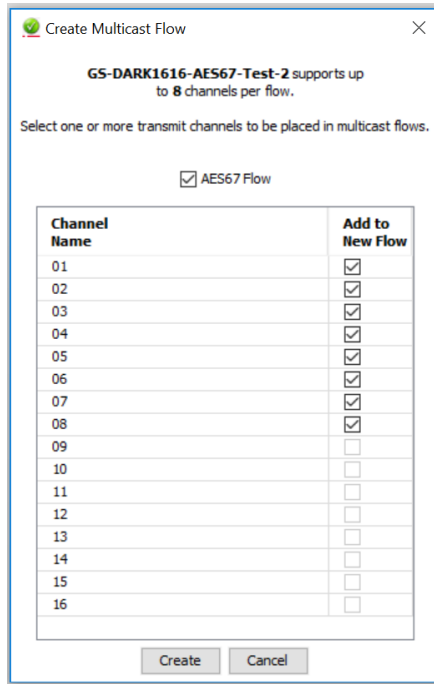

Tick the AES67 Flow check box, then select channels to be included in the flow then click 'Create'

Once set the flows can be seen in the transmit tab of the device view.

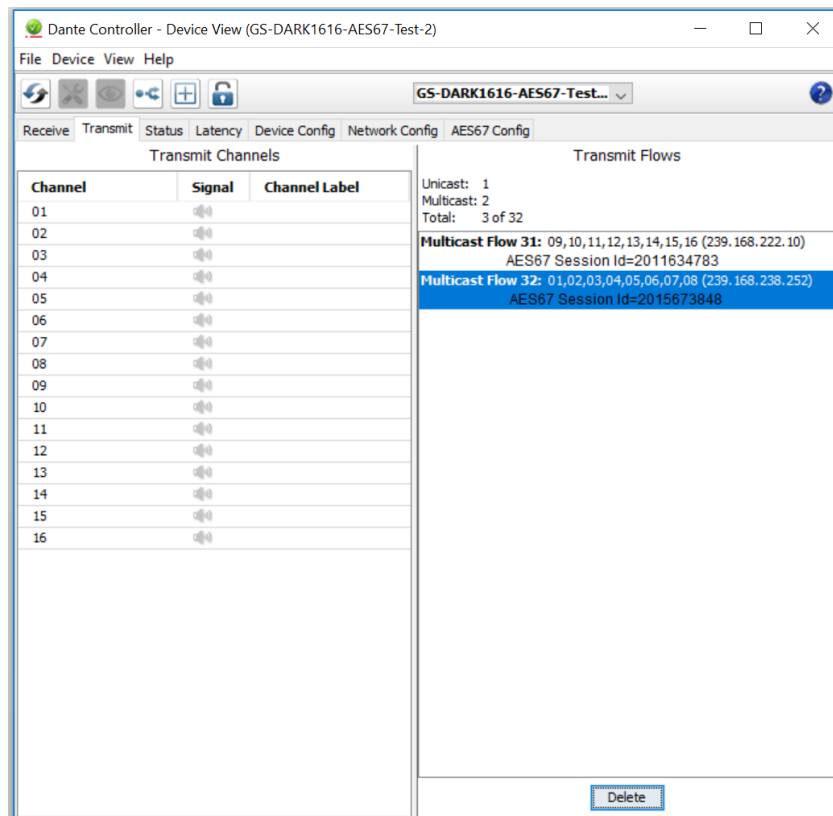

## Receiving AES67 Audio

Once a compatible AES67 stream is detected on the network by Dante Controller the AES67 flows will appear in the Dante Transmitters section in the Routing tab.

## **AES67 Restrictions**

AES67 flows can only be generated with the following constraints:

- Multicast Only
- Non-redundant
- Destination address in range 239.nnn.0.0 to 239.nnn.255.255 (239.nnn/16), port 5004
- 48kHz sampling rate
- 24 bit linear (L24) encoding
- 1 msec packet time
- Up to 8 channels per stream

Received AES67 flows have the following constraints:

- Multicast Only
- Non-redundant
- Destination address in range 239.nnn.0.0 to 239.nnn.255.255 (239.nnn/16), port 5004. Must match destination address range.
- 48kHz sampling rate
- L16 or L24 encoding
- 125usec, 250usec, 333usec, 1 msec packet time
- Up to 8 channels per stream

The Charles also supports SMPTE-ST2110-30 via Dante Domain Manager (DDM), with a license purchased from Audinate.

## Updating device firmware

### Equipment needed

- A Windows based PC
- USB type C cable
- A copy of 'DfuSe Demo' software
- The latest firmware from Glensound

### Instructions

#### **Download and install DfuSE Demo**

'DfuSE Demo' is a firmware updating tool that is required for loading new firmware on to the Charles.

It can be downloaded from the STMicroelectronics website found here: <https://goo.gl/AbzhsA>. It is the file named "STSW-STM32080".

Once you have downloaded this file you will need to extract the .exe "DfuSe\_Demo\_V3.0.5\_Setup.exe", then run and install it.

#### **Download firmware**

The latest firmware for the Charles will be provided to you upon request from Glensound. Please contact [sales@glen-sound.com](mailto:sales@glen-sound.com) if you wish to enquire about the latest Charles firmware.

Name	Date	Type	Size
 Dark1616S1.1.1.dfu	21/03/2018 11:18	DFU File	47 KB

Figure 1 Example filename

#### **Connect To A PC**



Figure 1 Rear panel USB connector

Connect the Charles to the PC via the USB cable. The USB connector is located on the rear panel of the Charles.

## Firmware update preparation

To prepare the Charles for a firmware update;

1. Press and hold down the Update button
2. Power on the unit

Your PC should make an audible sound when this process is successful as windows is detecting a new USB device.

## Loading the firmware

Now open DfuSe Demo.

If the Charles successfully entered DFU mode then it will appear as 'STM Device in DFU Mode' under the 'Available DFU Devices tab'.

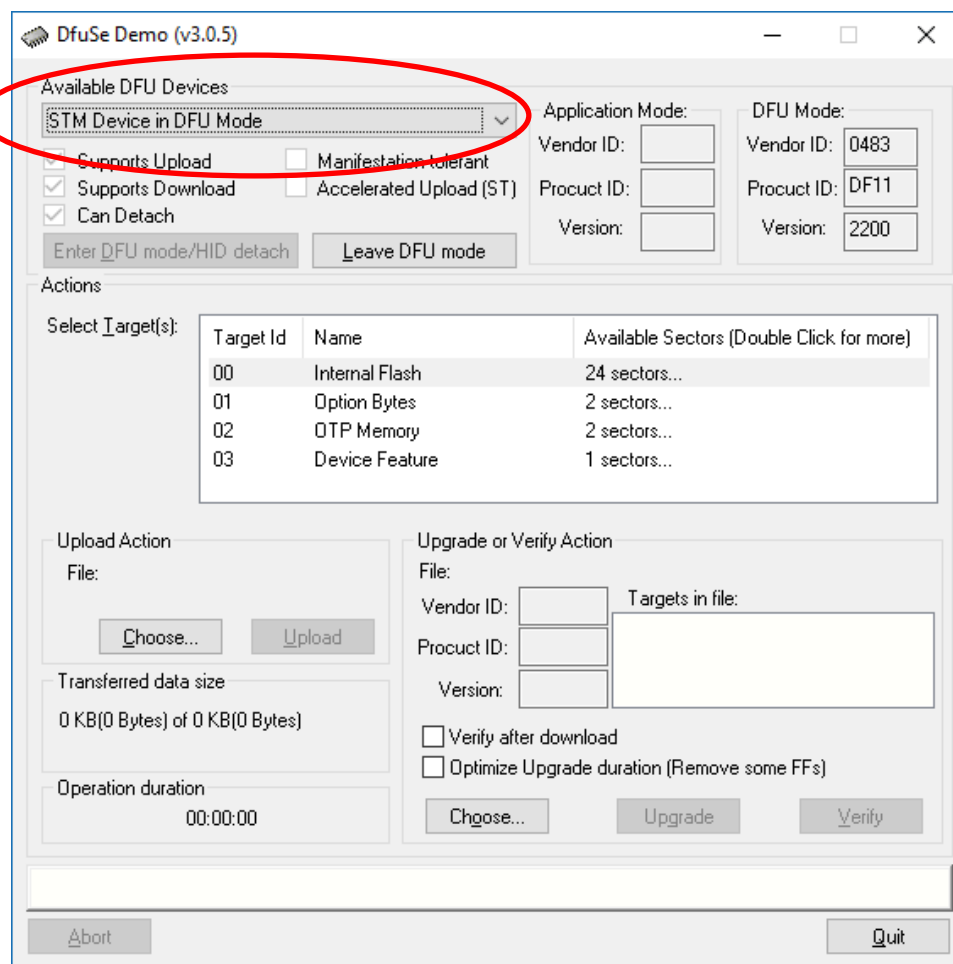

Figure 2 Device successfully recognised

Now the .dfu file needs to be selected so that DfuSe Demo knows the correct firmware to put on to the Charles.

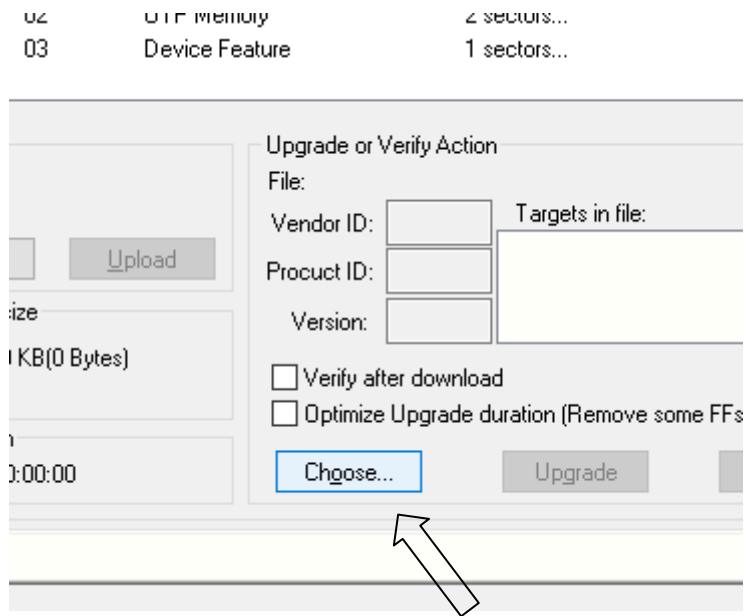

Figure 3 Choose .dfu file

Click choose and then select the .dfu file that GlenSound provided to you. This will be located in your downloads folder by default.

If the file loads successfully then it will read along the bottom 'File correctly loaded'.

### Upgrading the Charles firmware

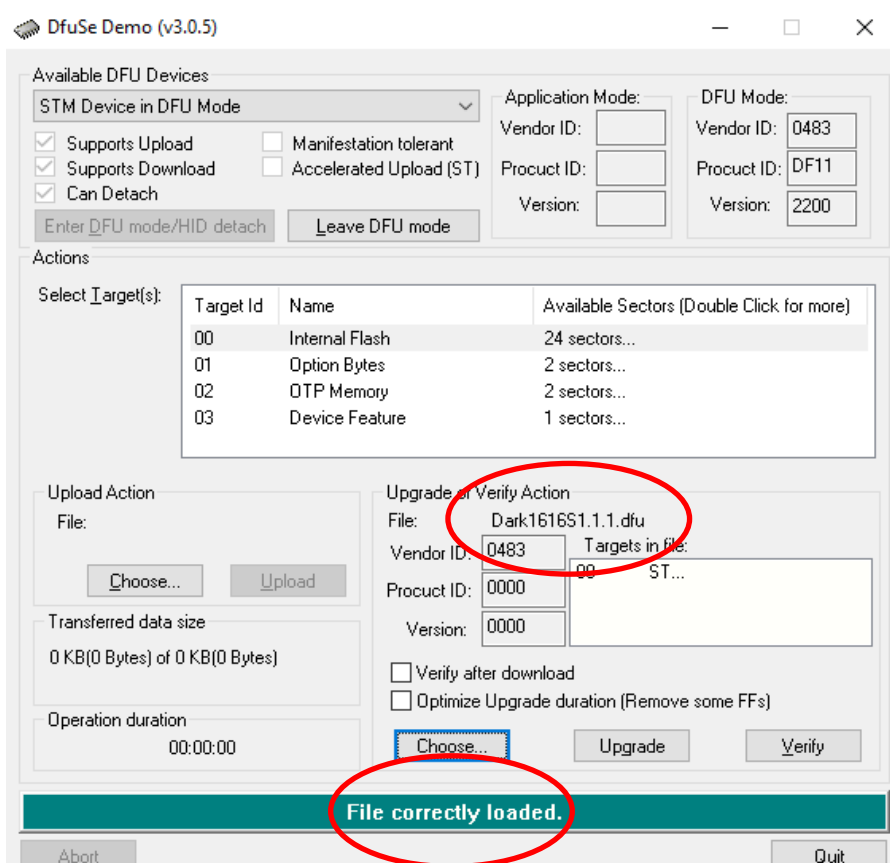

Figure 4 .dfu successfully loaded

The firmware is now ready to be put on to the Charles. Tick the 'Verify after download' box first and then click 'Upgrade'.

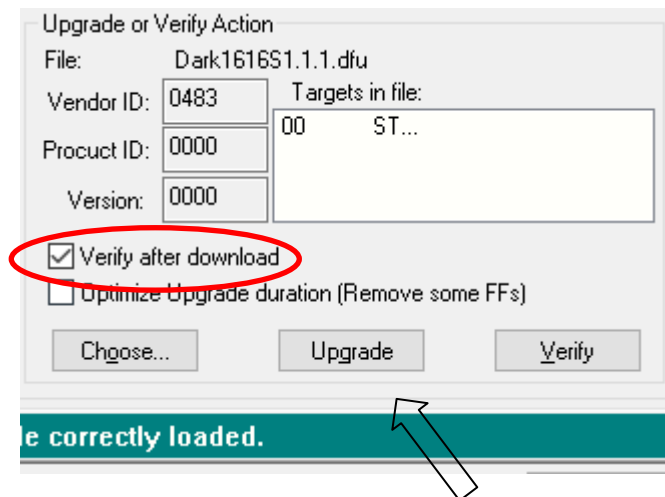

Figure 5 Upgrade

Click yes to proceed.

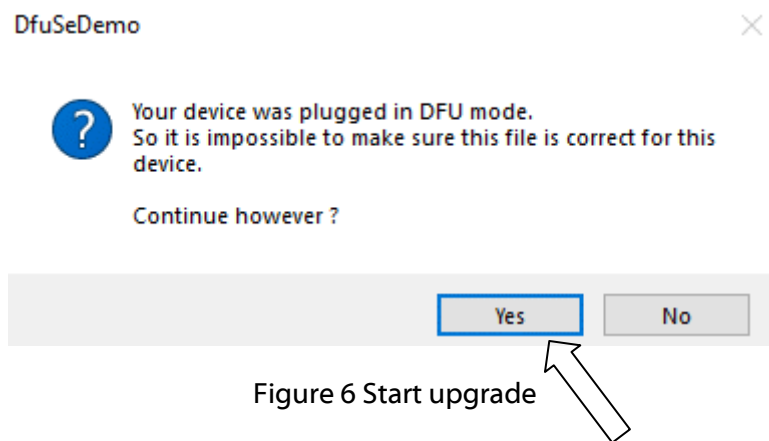

Figure 6 Start upgrade

The progress bar along the bottom will show the status of the operation.

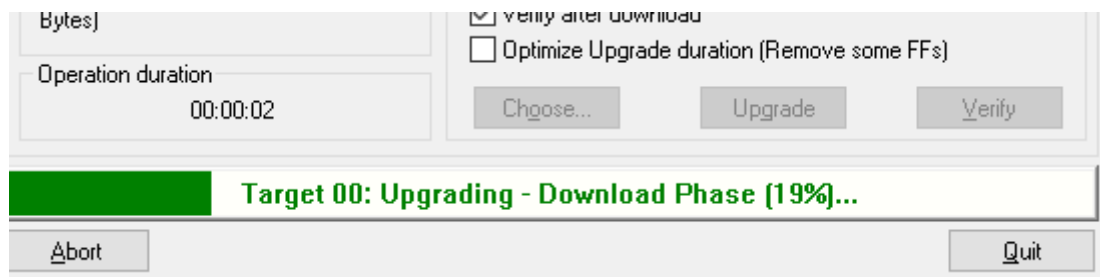

Figure 7 Upgrade status



If the operation was successful, DfuSe Demo will report that "Target 00: Verify Successful!".

You may also see that it will report how much data was successfully transferred.

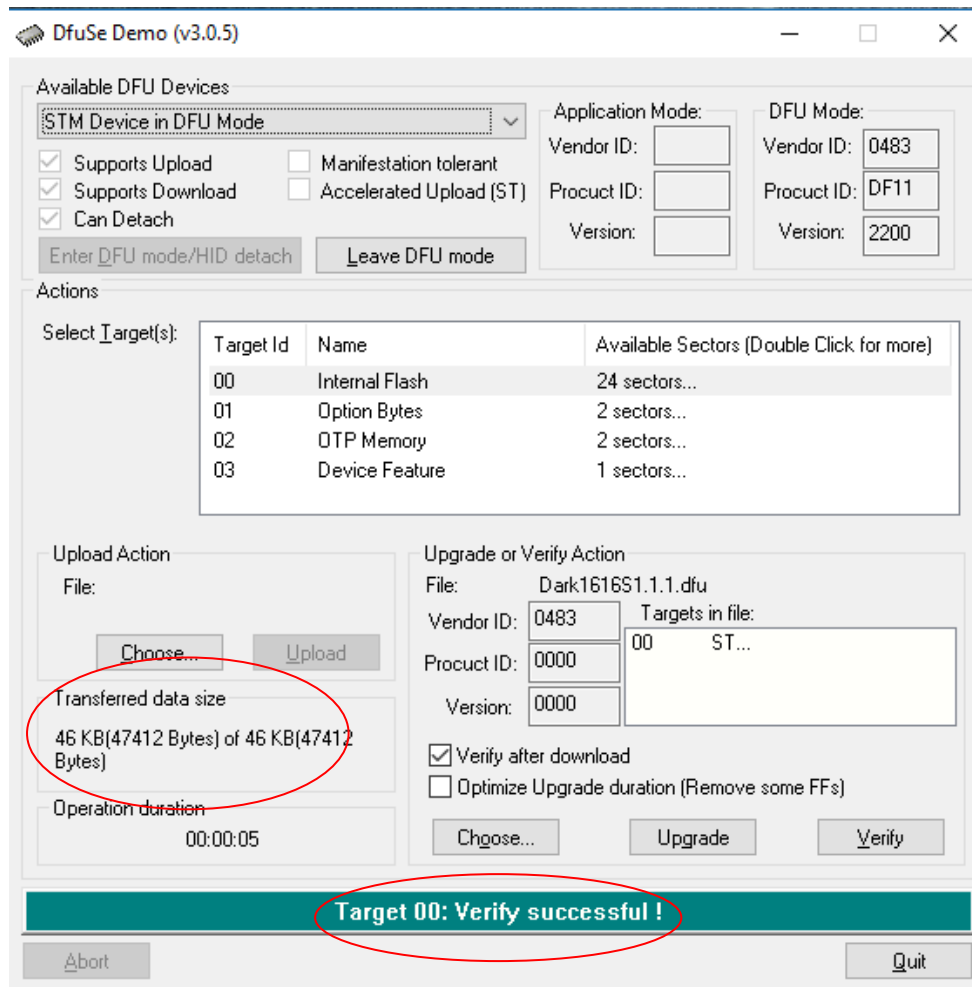

Figure 8 Successful upgrade!

## Final steps

Now click "Leave DFU mode" to finish the procedure.

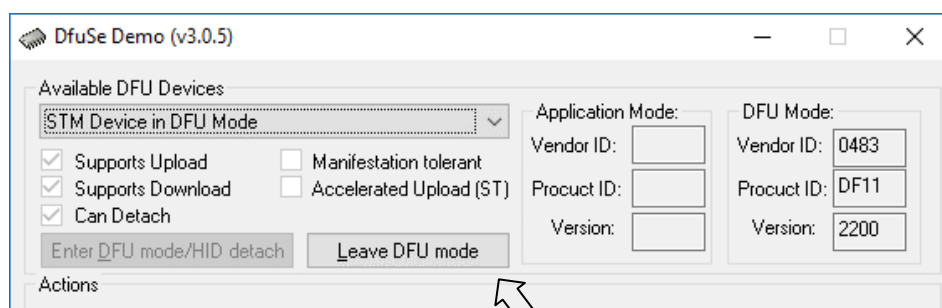

Figure 9 Final step

You may now disconnect the USB cable and continue to use the Charles with the freshly updated firmware!

## Updating the Dante firmware

The Charles has Dante specific firmware that runs inside the Dante chipset, known as Brooklyn.

The Brooklyn Chipset is a device supplied by Audinate that does most of the processing for the actual Dante/ AES67 network audio streams. There is one Brooklyn Chipset in each Charles.

## Updating the device

The firmware that runs in the Brooklyn Chipset can be updated using the built-in Dante Updater in Dante Controller. Please ensure you have a connection to the internet.

*If you want to update devices on a Dante network that is not connected to the Internet, you can download the files ahead of time to your computer, move the computer to the offline network, and then update the devices using the downloaded files.*

*Dante Updater displays a list of all online firmware files in the Library tab, so you can choose which files to download, or even download the entire database if you are not sure which files you will need. For further details please visit [www.audinate.com](http://www.audinate.com)*

1.

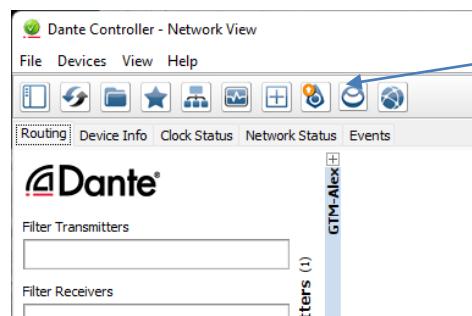

Dante controller notifies you if a device on your network is out of date.

Click the icon

2.

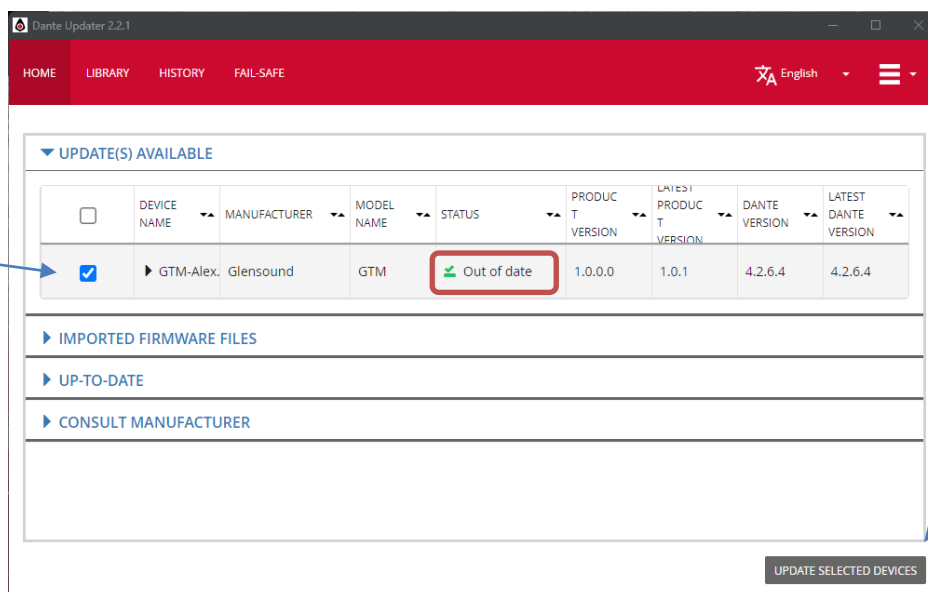

A. Tick the box to choose your unit for updating

B. Press to update device

3.

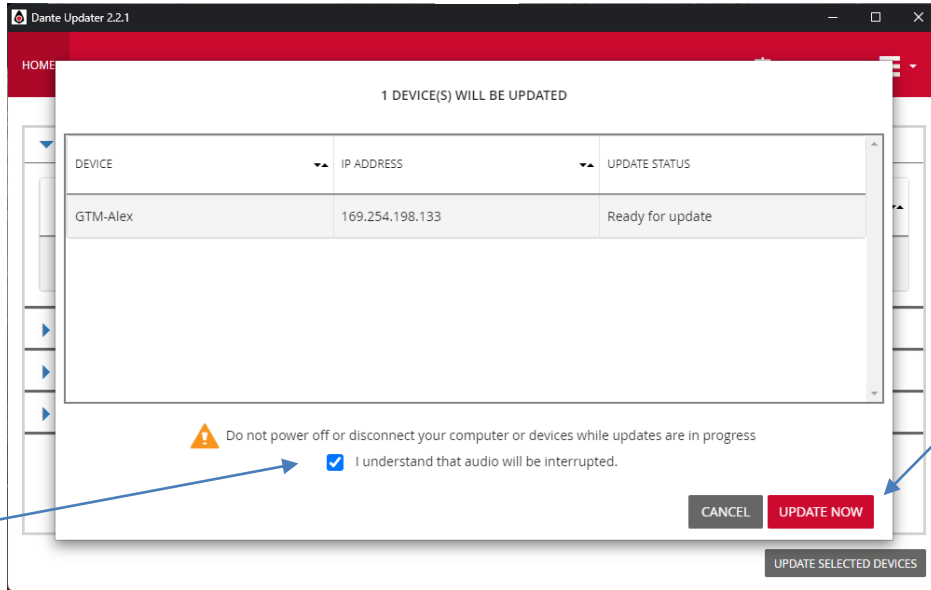

Caution! Audio will be interrupted during the device update

A. Tick box to confirm

B. Press to update device

4.

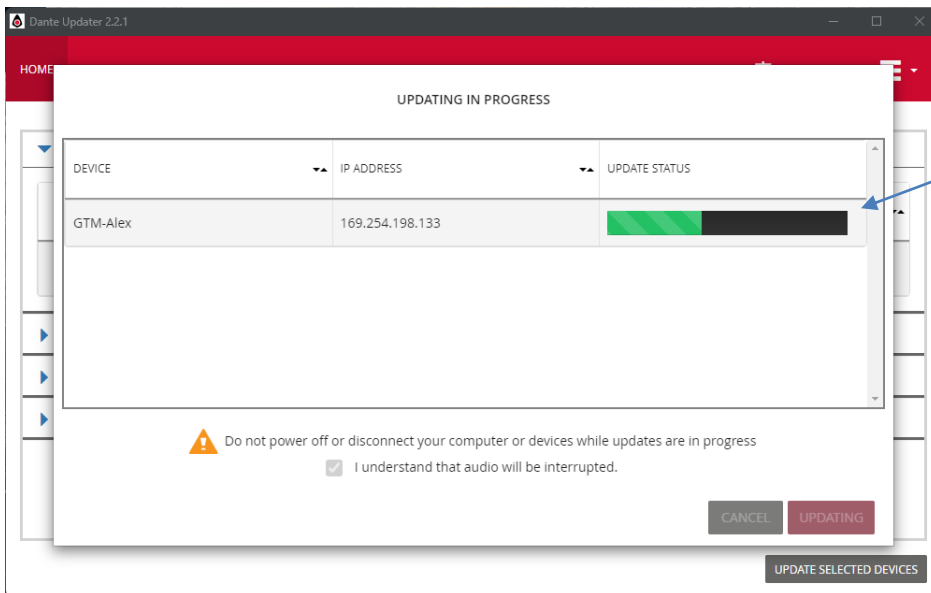

Update is in progress

5.

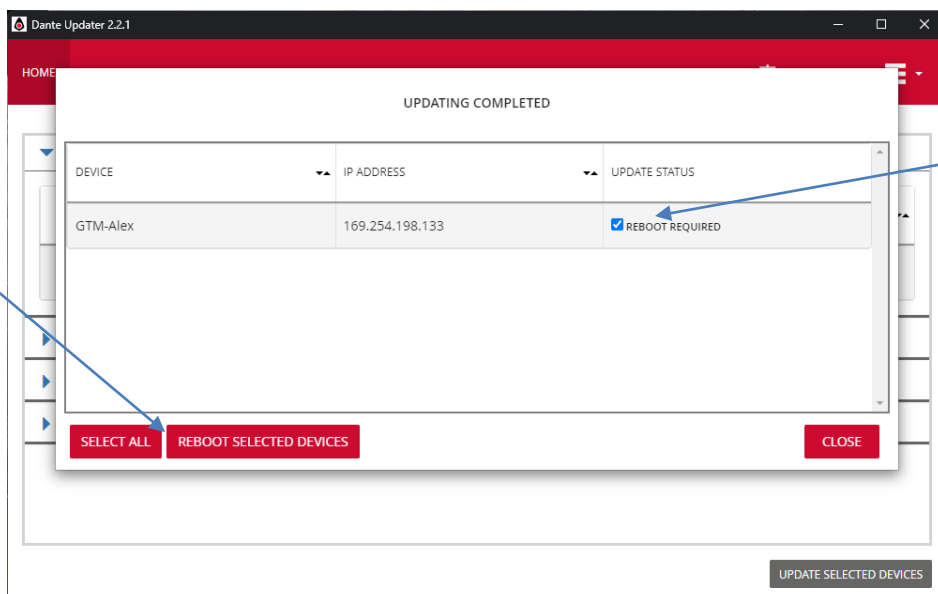

A. Update finished. Tick box to continue

B. Press to reboot device

Update finished, device will now reboot

## Wiring Information

### XLR & Jack Wiring

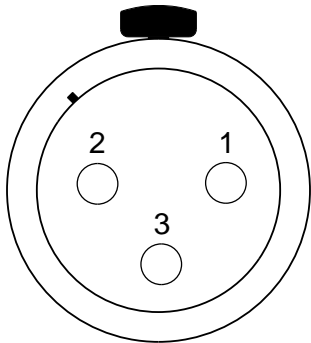

XLR SOCKET (FEMALE)

#### STANDARD XLR AUDIO PINOUTS:

**1: Ground/ Earth**

**2: INPHASE/ POSITIVE/ MIC +**

**3: MATE/ NEGATIVE/ MIC -**



#### STANDARD HEADPHONE WIRING:

**TIP: A/ LEFT Ear**

**RING: B/ RIGHT Ear**

**SLEEVE: Ground / Earth**

### Optional 5 Or 4 Pin XLR Wiring Information

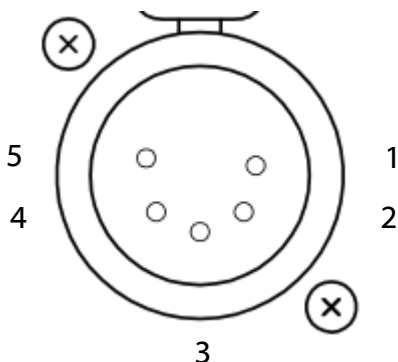

#### 5 PIN XLR AUDIO PINOUTS:

*Female XLR fitted to Charles, mates with cable mounted male*

**1: MATE/ NEGATIVE/ MIC -**

**2: INPHASE/ POSITIVE/ MIC +**

**3: GROUND/ EARTH**

**4: HEADPHONE LEFT**

**5: HEADPHONE RIGHT**

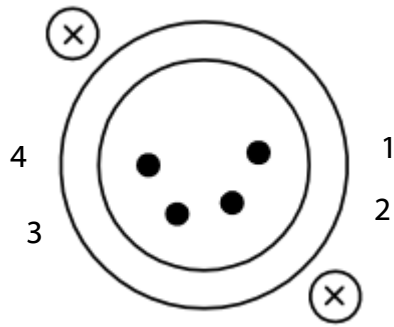

**4 PIN XLR AUDIO PINOUTS:**

*Male XLR fitted to Charles, mates with cable mounted female*

**1: MIC GND/ MIC -**

**2: INPHASE/ POSITIVE/ MIC +**

**3: HEADPHONE GND**

**4: POSITIVE/ HEADPHONE +**